

NOTES: UNLESS OTHERWISE SPECIFIED

1. MANUFACTURED AND INSPECTED IAW AS9100 QUALITY SYSTEM REQUIREMENTS.
2. ABBREVIATION USED IN TITLE IS: VALVE REGULATED SEALED LEAD ACID (VRSLA).
3. SEE DRAWING NO. CB-00458 AND PROCEDURE P-1000 FOR ASSEMBLY AND TEST INSTRUCTION. PROCEDURES AND ASSEMBLY DRAWINGS ARE FOR INTERNAL USE ONLY.
4. BATTERIES ARE RATED IAW INTERNATIONAL ELECTROTECHNICAL COMMISSION STANDARD 60952-1 AND RTCA STANDARD DO-293A, UNLESS OTHERWISE NOTED.
5. DIMENSIONS ARE INCH [MILLIMETER].

REVISIONS			
REV	DESCRIPTION	DATE	APPROVED
A	REVISED FOR TSO TESTING, REDRAWN IN SOLIDWORKS	1/31/18	PH

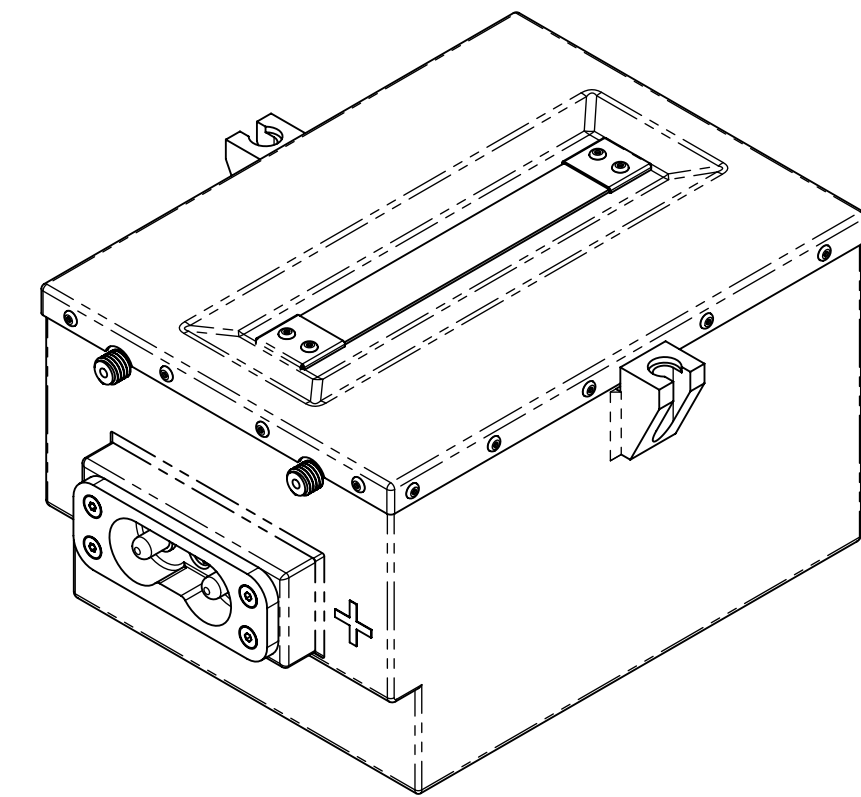
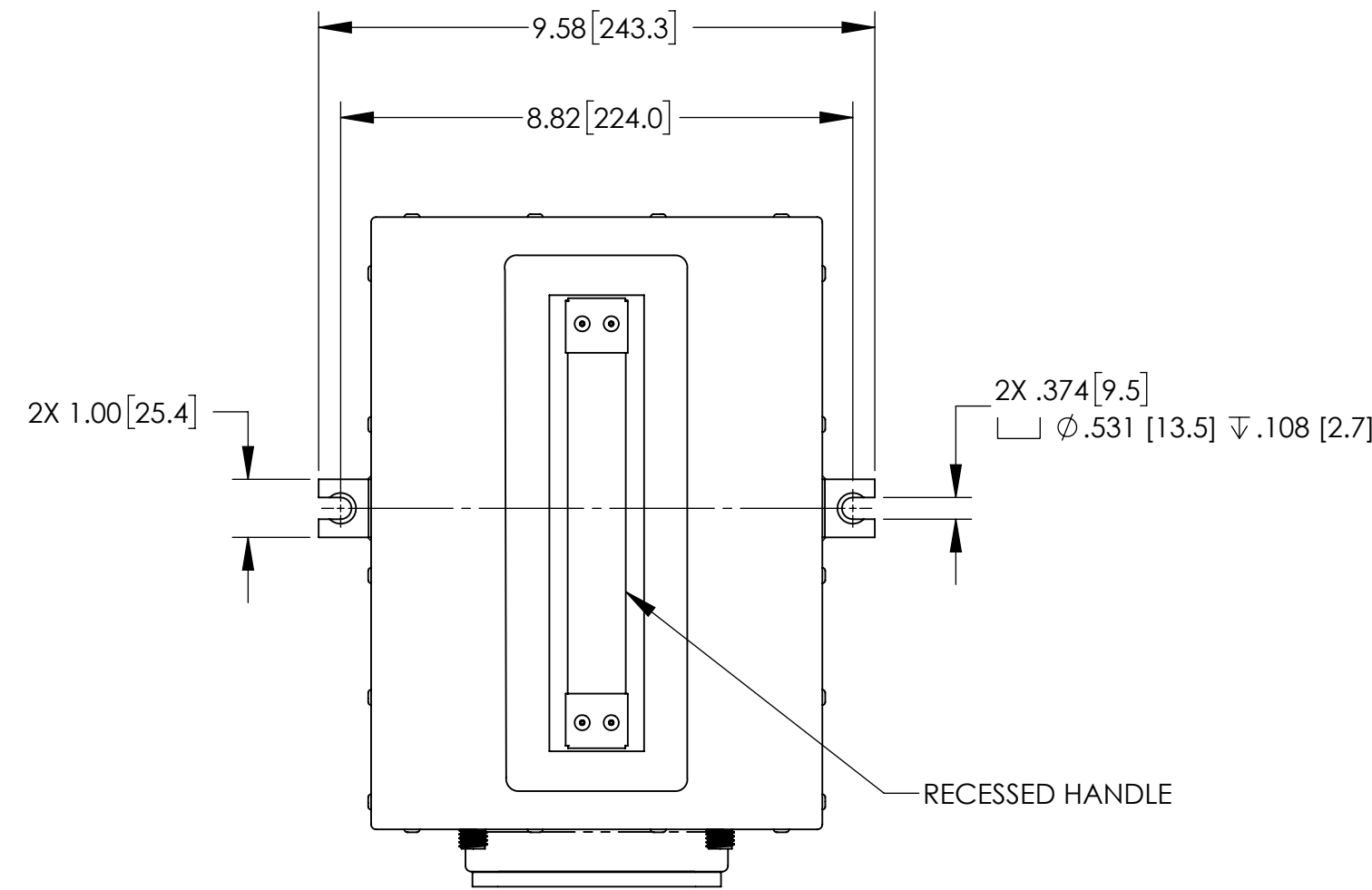

REFERENCE VIEW

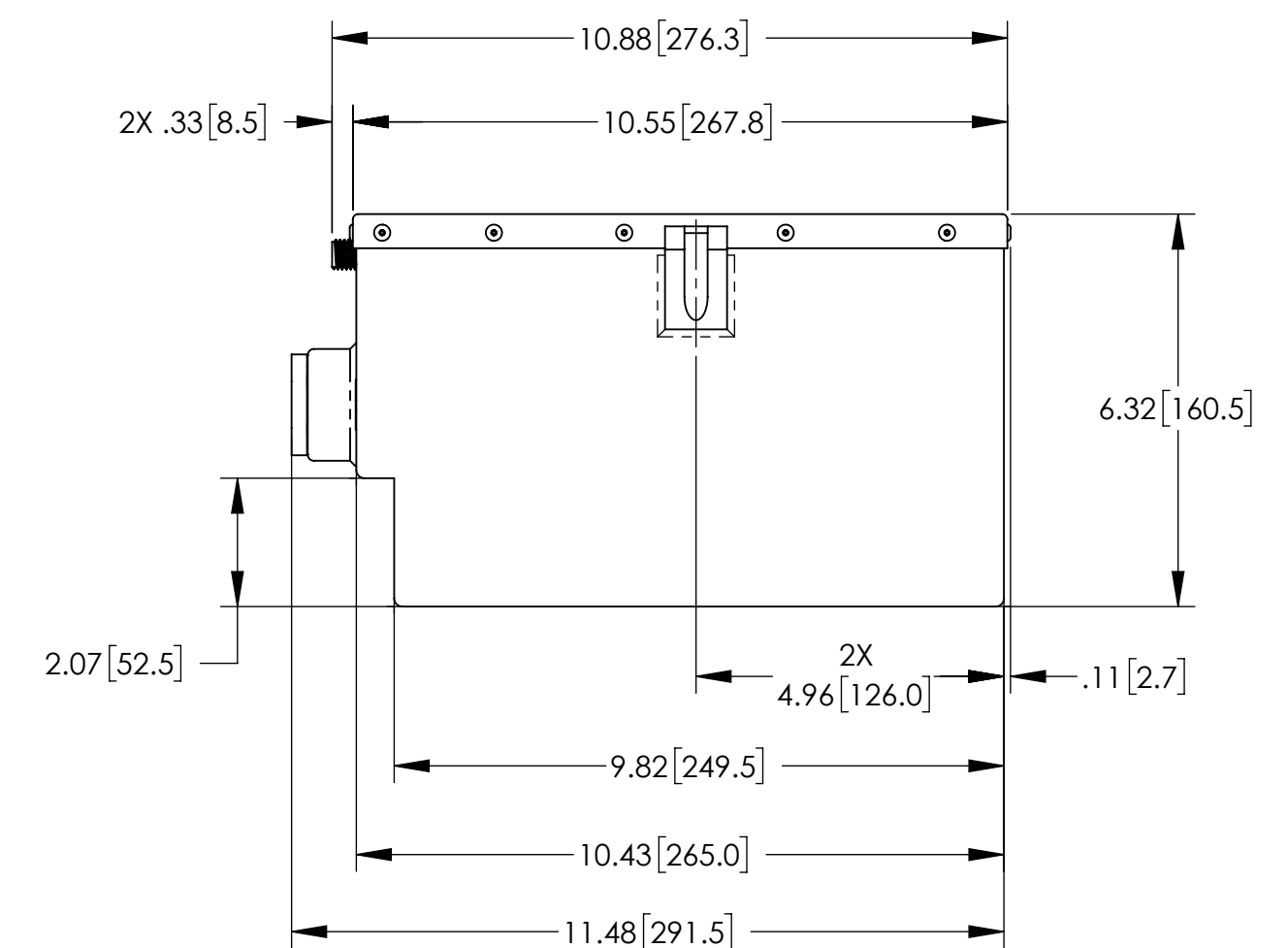
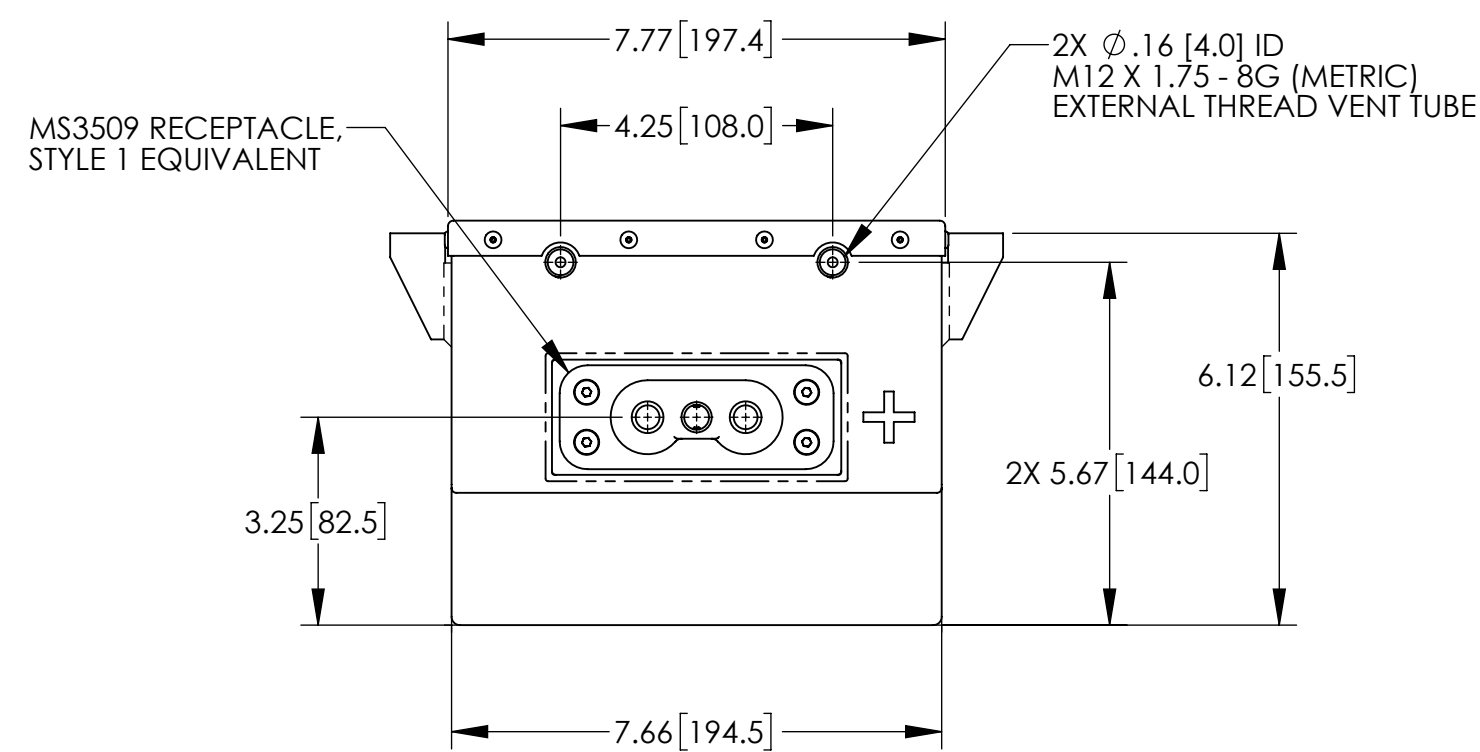

ENVELOPE DRAWING

PART NUMBER	RG-445E
MAXIMUM WEIGHT	43 LBS [19.5 KG]
RATED CAPACITY, C ₁	18 AH
POWER RATING AT 23°C	I _{pp} 1050 A, I _{pr} 700 A
POWER RATING AT -18°C	I _{pp} 725 A, I _{pr} 575 A
POWER RATING AT -30°C	I _{pp} 550 A, I _{pr} 375 A

UNLESS OTHERWISE SPECIFIED DIMENSIONS ARE IN INCHES TOLERANCES ARE:			CONTRACT NO.		CONCORDE BATTERY CORPORATION 2009 SAN BERNARDINO RD, W. COVINA, CA 91790			
FRACTIONS	DECIMALS	ANGLES	APPROVALS		DATE		TITLE	
±1/32	.XX ±.06 .XXX ±.030	±1°	DRAWN HRF		8/7/00		BATTERY, VRSLA, 24 VOLT	
TREATMENT	NONE		CHECKED AMIII		5/17/01		SIZE	CAGE CODE
FINISH	NONE		APPROVED JBT		5/17/01		C	63017
SIMILAR TO	CALC WT		ISSUED JG		2/1/18		DWG NO.	REV
							RG-445E	A
SCALE 1:3							SHEET 1 OF 1	